



TRACTION

Your partner for high voltage
rolling stock systems



ALPHA-ET

Current and voltage – our passion

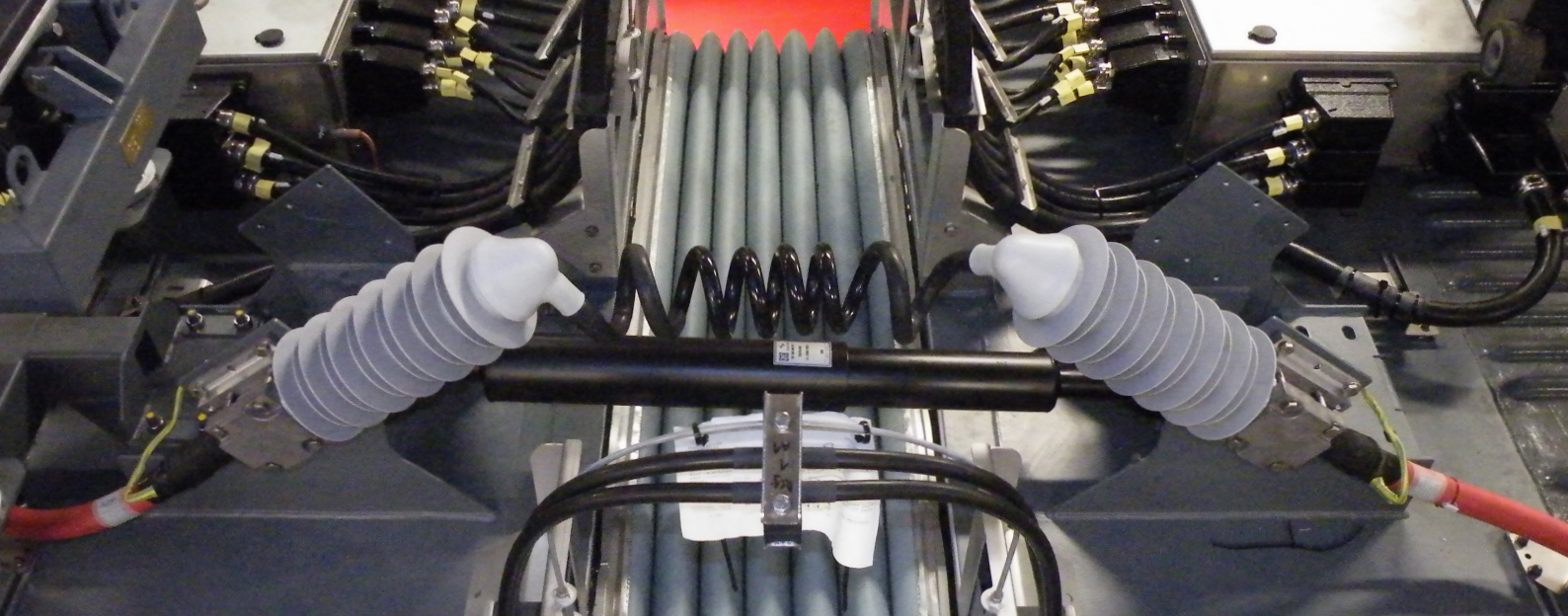

ALPHA Elektrotechnik, Current and voltage - our passion

Established over 90 years ago in Nidau, Switzerland, ALPHA Elektrotechnik AG is a company steeped in tradition. Starting out in the power transmission business selling disconnectors for medium- and high-voltage networks, ALPHA also has a separate business unit – “cable solutions” – for the transfer of energy in high voltage systems of modern railways.

First-class engineering ensures continuous further development and guarantees that end products are of high quality. An extremely efficient supply chain gives us a high level of flexibility, thereby enabling us to take on projects of various sizes. The international references we have received are an impressive indicator of the quality of our products and services.

Our disconnectors have been used around the world for a number of decades and have proved to be very efficient under a wide range of conditions. The power transmission technology on high-speed trains functions reliably and ensures that trains operate safely. The reliability of our products and the fact that they are guaranteed to function for a number of years are major indicators of quality. In addition, we guarantee an outstanding level of service provided with the products, as well as on-site installation of technology and training sessions.

The company is located right in the centre of the Swiss watch industry. The area is well-known for its exceptional expertise in precision mechanics and its skilled workers. ALPHA employs a number of staff who have been at the company for many years, bringing with them a high degree of expertise and excellent manufacturing skills.

In 2015, ALPHA became a member of the PFIFFNER Group (headquartered in Hirschthal, Switzerland) to preserve the continuity of the company. ALPHA is supplementing the core business in the field of instrument transformers. With the bushings produced by MGC Moser-Glaser Ltd. and the powerful market position of the international subsidiaries, the PFIFFNER Group with ALPHA-ET, offers a very broad range of products for customers and distribution partners for the transfer of energy in networks of all voltage types.

TRACTION – connection systems

Durable and reliable in service

In 1999, ALPHA Elektrotechnik AG started to develop and produce high voltage assemblies for railways (traction) from 3 kV to 25 kV. Thanks to its high level of quality and flexibility, ALPHA has a reference list of over 300 projects in the international railway sector.

The heart of the transmission process is the partially insulated or fully insulated pluggable jumper. Jumpers are car2car connections to ensure the distribution of energy between rail cars, particularly on commuter trains and high-speed trains. ALPHA masters one of the principal difficulties, which consists in reconciling flexibility and resistance in order to make it possible that the cable supports millions of torsion movements, resonance extreme climatic conditions. We guarantee a high-quality standard on a long lifetime of the cable documented with different internal tests. In addition we offer different services as customer-specific engineering, installation and training on-site, repair work, etc.

We manufacture both ends of the cable according to the customer's requirements. In line with the concept of providing tailored solutions, we offer a range of cable cross sections regardless of the chosen type of cable termination or connector. All products meet the relevant railway standards and the applicable fire protection standard DIN EN 45545-2.

Connector systems: Durable and reliable in service – customised to your requirements

Content

■ Product Overview	4
■ Solutions	6
Flexible termination	
Roof termination	
Pluggable termination	
Spiral jumper	
Fully insulated jumper	
■ Portable Partial Discharge Test System	11
■ Services	12
■ Services - Case study retrofit	13
■ Special Test	14
■ Team Traction / Contact	15

Product Overview

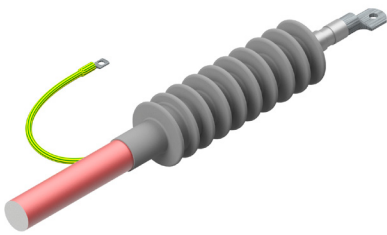

ESF-40S (3-25) kV

- Flexible termination
- U_{max} : 36/42 kV
- Cable cross section: 50–240 mm²
- Creeping distance: 250–1300 mm

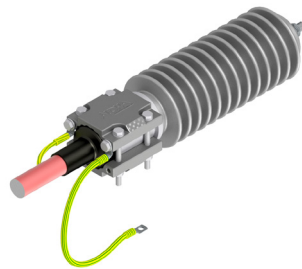

ESF-RS (3-25) kV

- Rigid termination
- U_{max} : 36/42 kV
- Cable cross section: 50–240 mm²
- Designed with clamps

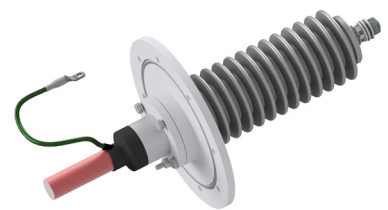

ESF-DS (3-25) kV

- Rigid termination
- U_{max} : 36/42 kV
- Cable cross section: 50–240 mm²
- Designed for flanges



ESF-S (3-25) kV

- Plugable termination
- U_{max} : 36/42 kV
- Cable cross section: 50–240 mm²

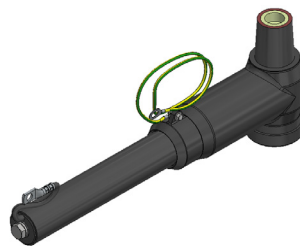

Surge arrester

- Metaloxide surge arrester
- Connector Type CB/CC
- U_c : 16.8–42 kV
- In 5–10 kA



Trafo Plug

- Screw on T/L-plug
- U_{max} : 36/42 kV
- Cable cross section: 50–400 mm²
- Type B/C/E



Spiral jumper

- Car to car connection
- Cable cross section: 95 mm²/120 mm²
- Length: 200 mm to 1000 mm
- Compatible with ESF-RS



CCS jumper

- Car to car connection
- U_N: 25 kV; U_{max}: 36/42 kV
- Cable cross section: 70 mm²/150 mm²
- Under corridor/between carriages/on the roof
- Fully insulated with connection system



Quick coupling, 3 kV

- Car to car connection
- U_N: 3 kV; U_{max}: 4.5 kV (DC)
- Cable cross section: 95-240 mm²
- Fully insulated

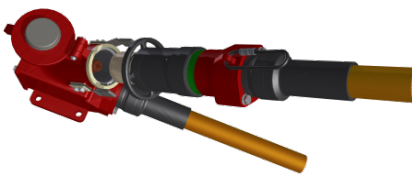

Preheating cable

- U_N: 100 V
- With safety contact

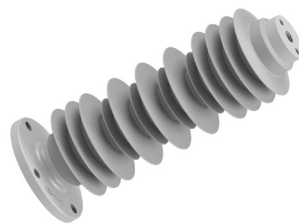

Post insulator

- U_N: 25 kV/36 kV
- Silicone sheds
- Various head and end fittings



Current transformer

- Precision class: 0.5 R
- Cross sect: 50 - 115 mm
- Fixing via mounting holes or panel

Solution with flexible termination

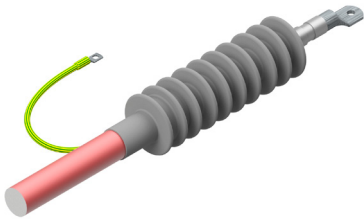
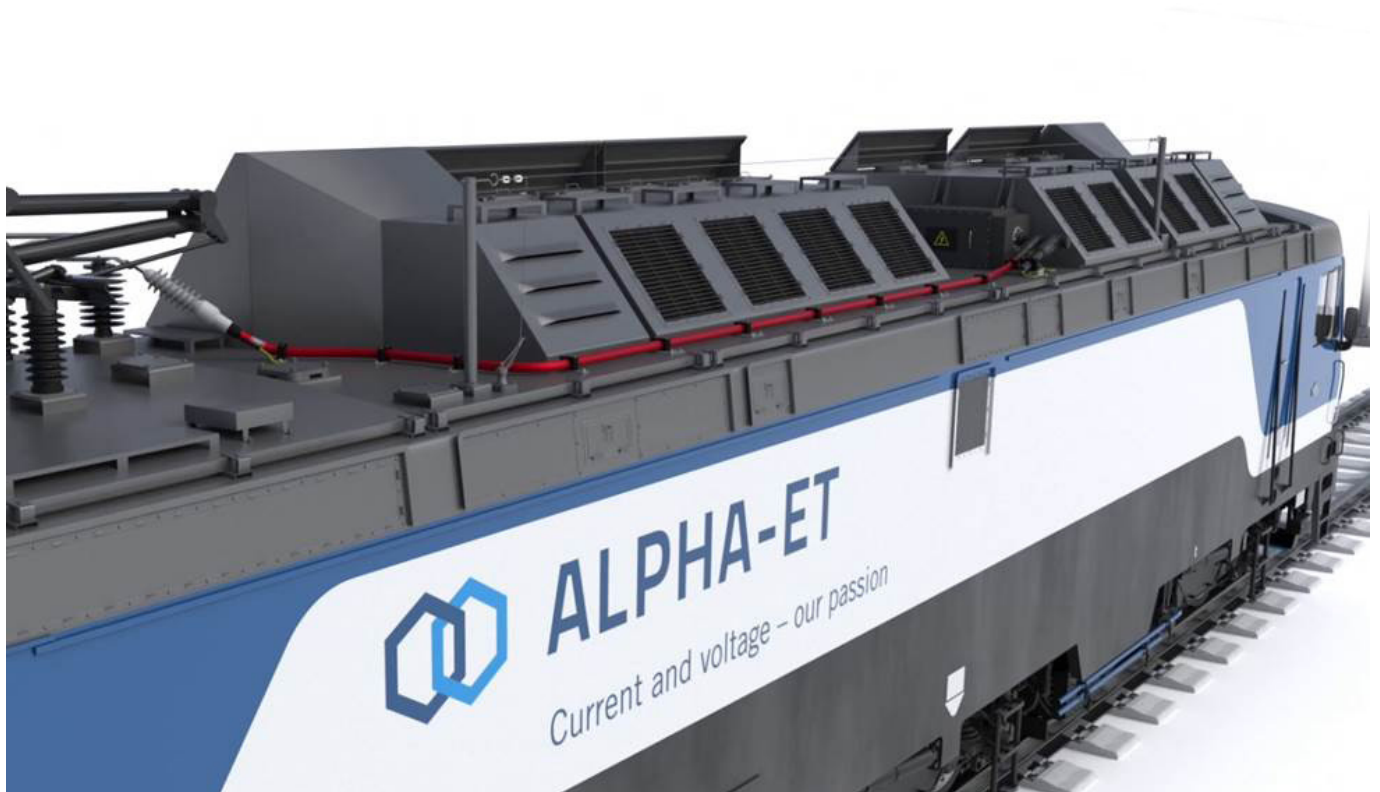

ESF40S (3-25) kV

- Flexible termination
- U_{max} : 36/42 kV
- Cable cross section: 50-240 mm²
- Creeping distance: 250-1300 mm



Transformer plug

- Screw on T/L-plug
- U_{max} : 36/42 kV
- Cable cross section: 50-400 mm²
- Type B/C/E

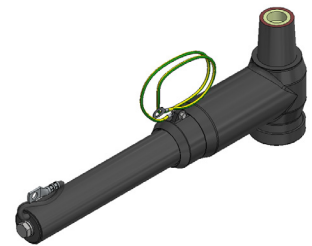

Surge arrester (15-25) kV

- Metaloxide surge arrester
- Connector Type CB/CC
- U_c : 16.8-42 kV
- In 5-10 kA

References / Total over 100 projects including:



KISS, 19 units

- Stadler Rail
- USA
- Caltrain



Talent 2 & 3, over 100 units

- Bombardier Transportation
- Austria & Germany
- ÖBB & Vlexx



X60, approx. 50 units

- Alstom
- Germany
- MTR Nordic

Solution with roof termination

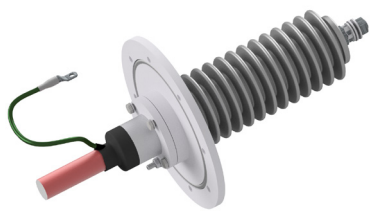
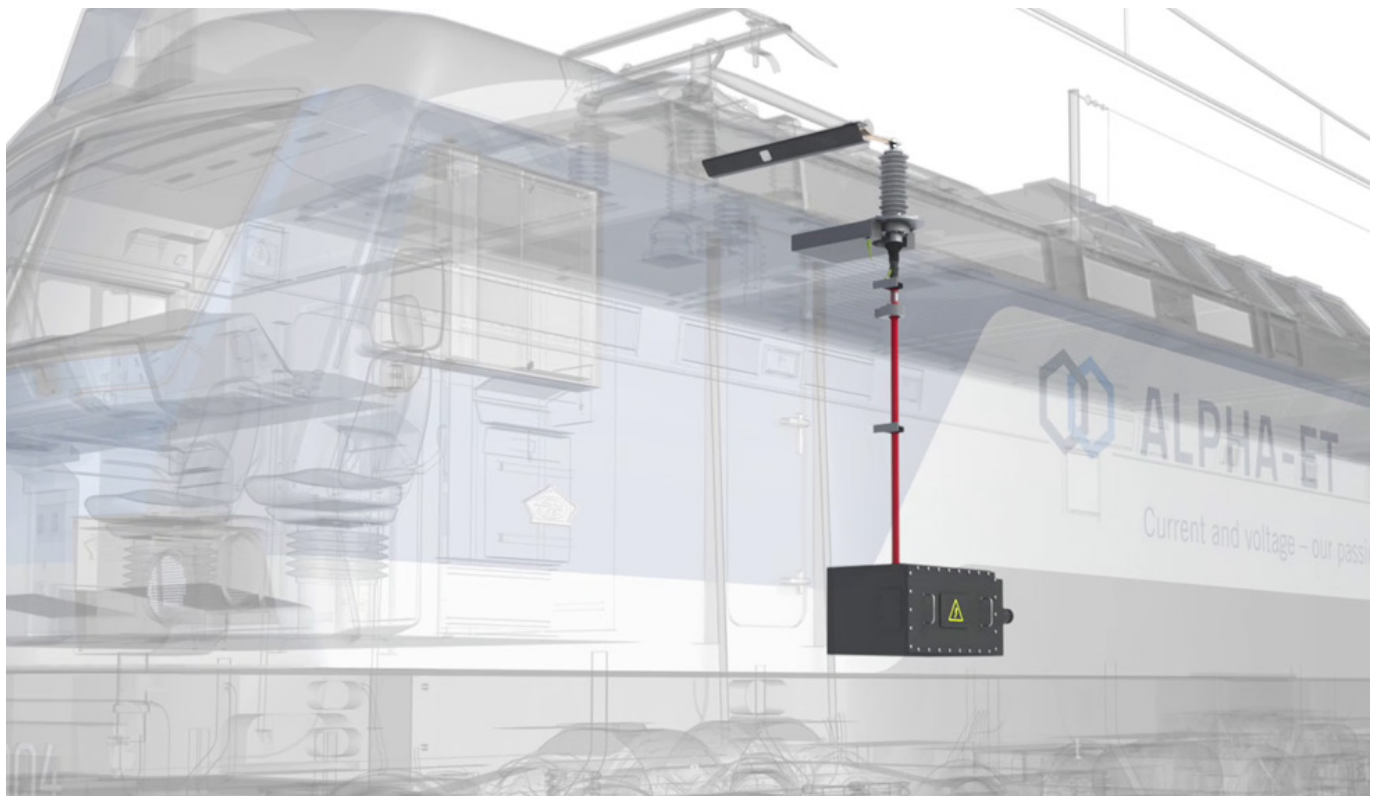

ESF-DS (3-25) kV

- Rigid termination
- U_{max} : 36/42 kV
- Cable cross section: 50–240 mm²
- Designed for flanges



Transformer plug

- Screw on T/L-plug
- U_{max} : 36/42 kV
- Cable cross section: 50–400 mm²
- Type B/C/E

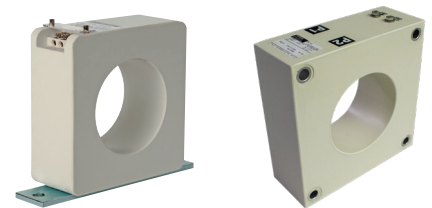

Current transformer

- Precision class: 0.5 R
- Cross sect: 50-115mm
- Fixing via mounting holes or panel

References / Total over 80 projects including:



Ee 922, 25 Un./Eem 923, 30 Un.

- Stadler Winterthur AG
- Switzerland
- Swiss Railways & Cargo



AT 300/400 over 200 units

- Hitachi Rail
- UK
- IEP, ASR, WOE, TPE & HULL



TGV, 30 units

- Alstom
- Marroco
- RGV Maroc

Solution with pluggable termination

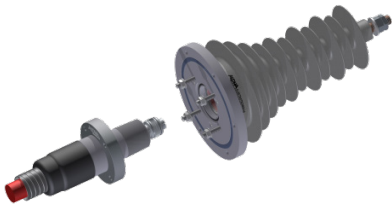
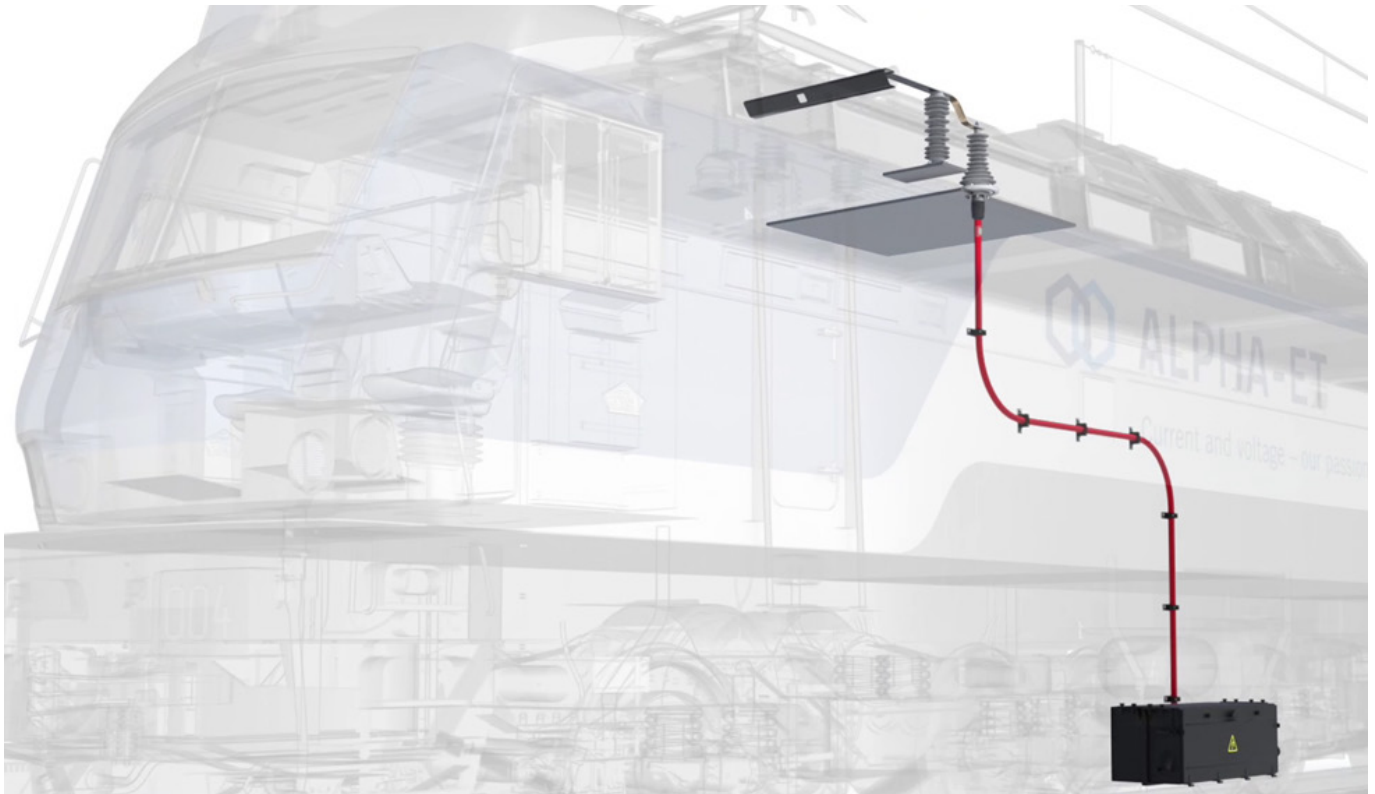

ESF-S (3–25) kV

- Pluggable termination
- U_{max} : 36/42 kV
- Cable cross section: 50–240 mm²

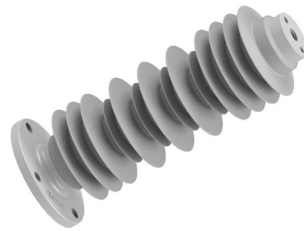

Post insulator

- U_N : 25 kV/36 kV
- Silicone shield
- Various head and end fittings



Transformer plug

- Screw on T/L-plug
- U_{max} : 36/42 kV
- Cable cross section: 50–400 mm²
- Type B/C/E

References:



KZ8A, approx. 200 double units

- Alstom / EKZ / Astana
- France / Kazakhstan
- Kazakhstan Rail



KZ4A, approx. 50 units

- Alstom / EKZ / Astana
- France / Kazakhstan
- Kazakhstan Rail



Prima H4, approx. 47 units

- Alstom Belfort
- France
- Swiss Railways

Solution with spiral jumper

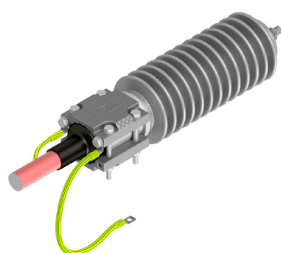
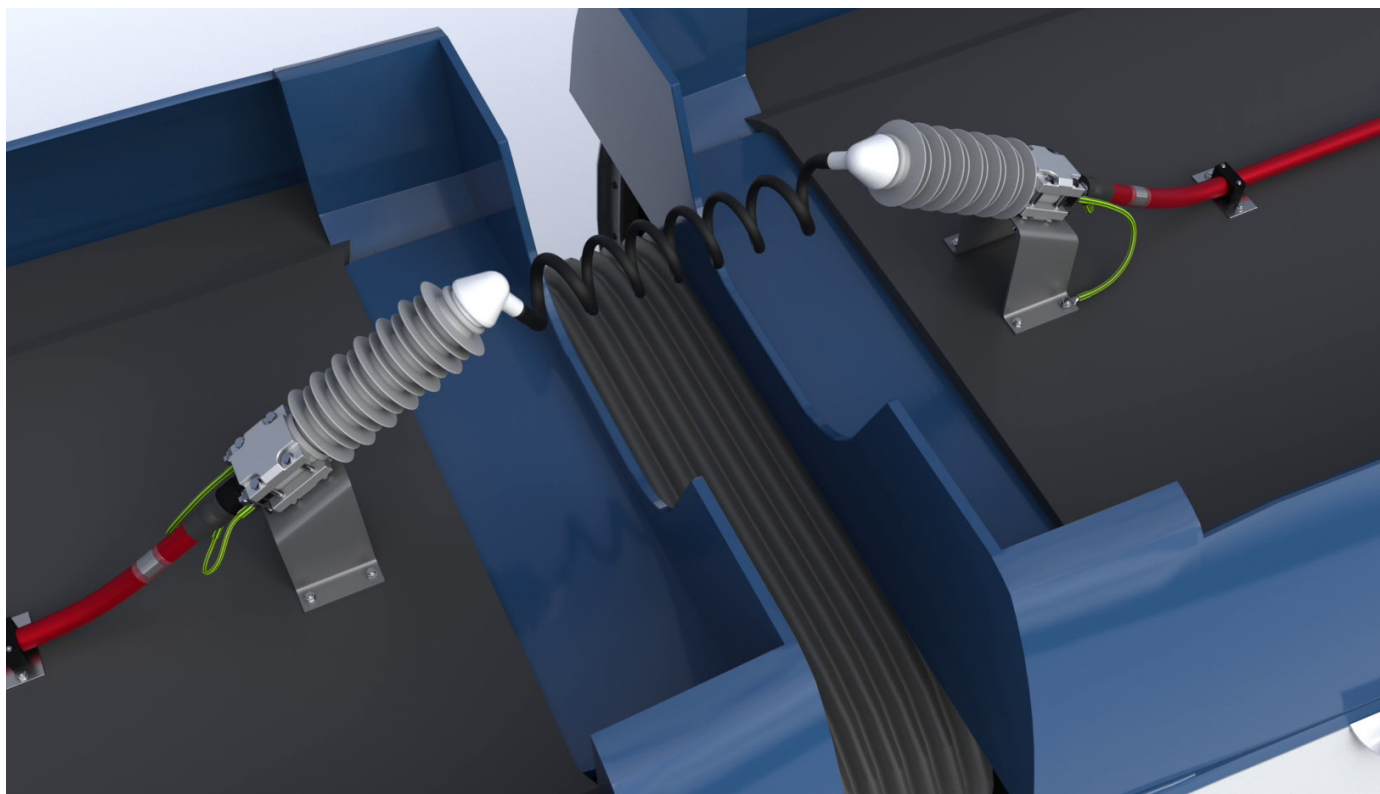

ESF-RS (3-25) kV

- Rigid termination
- U_{max} : 36/42kV
- Cable cross section: 50–240mm²
- Designed with clamps



Rigid terminal + Jumper

- Car to car connection
- Cable cross section: 95mm²/120mm²
- Length: 200mm to 1000mm
- Compatible with ESF-RS



Flexible terminal + Post insulator + Jumper

- Car to car connection
- Cable cross section: 95 mm²/120mm²
- Length: 200 mm to 1000 mm
- Compatible with ESF-40S

References / Total over 80 projects including:



Coradia XCC, approx. 30 units

- Alstom Transportation, Salzgitter
- Germany
- DB Regio AG



AT 300/400, over 200 units

- Hitachi Rail
- Japan, UK
- IEP, ASR, WOE, TPE & HULL



Desiro, approx. 50 units

- Siemens
- Russia, UK
- Russian Railways & various UK operators

Solution with fully insulated jumper

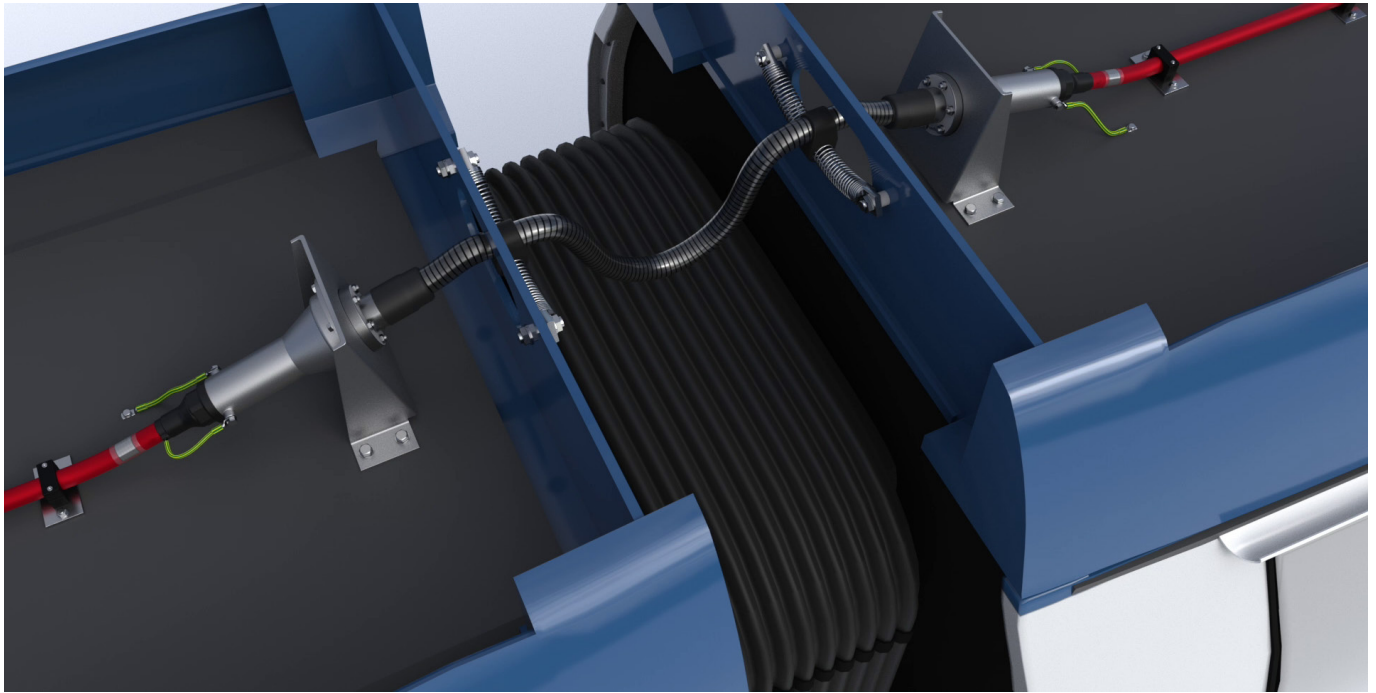

CCS Jumper

- Car to car connection
- U_N : 25 kV; U_{max} : 36/42 kV
- Cable cross section: 70 mm²/150 mm²
- Under corridor/between carriages/on the roof
- Fully insulated with connection system

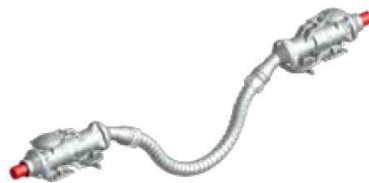

Quick coupling, 3 kV

- Car to car connection
- U_N : 3 kV; U_{max} : 4.5 kV (DC)
- Cable cross section: 95-240 mm²
- Fully insulated

References



TWINDEXX, approx. 59 units

- Bombardier Transportation
- Germany, Switzerland, Belgium
- Swiss Railways



Zefiro 380, approx. 90 units

- Bombardier Sifang
- China
- China Railways



Zefiro ETR 1000, approx. 60 uni.

- Bombardier Transportation
- Italy
- Trenitalia

Portable Partial Discharge Test System

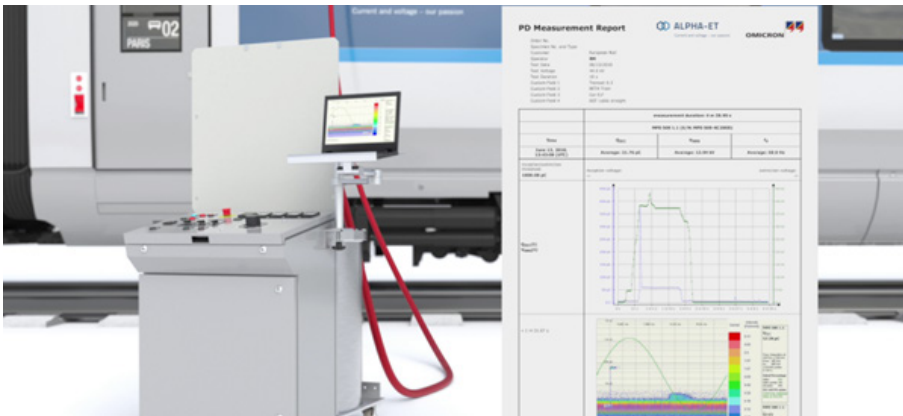
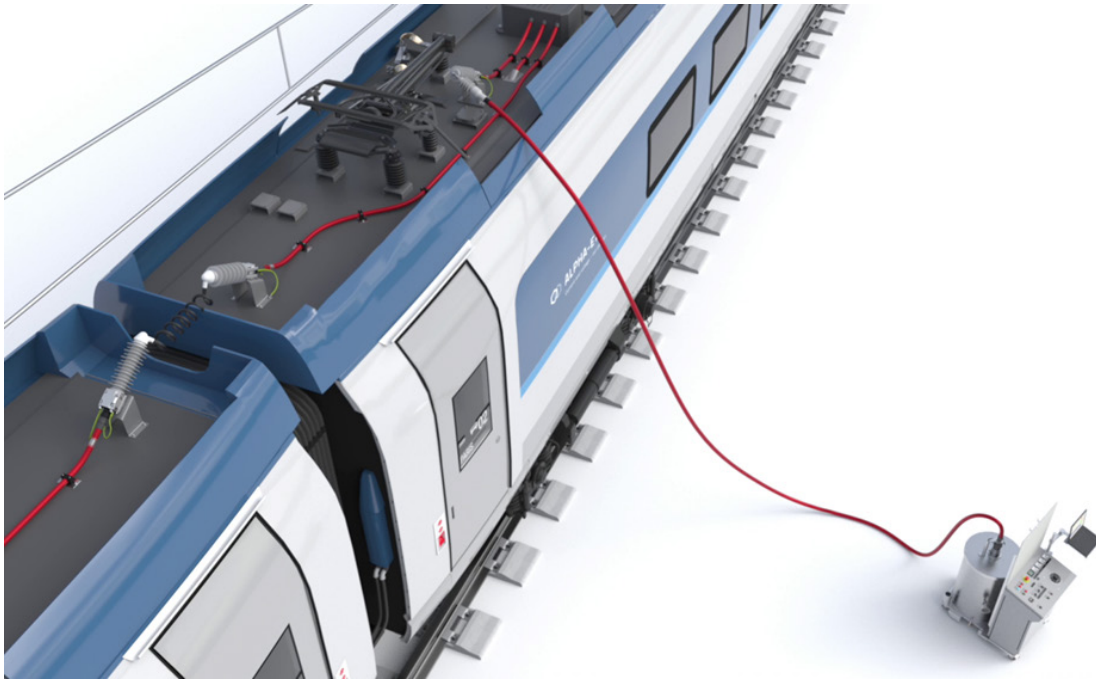

Portable test system

- Withstand voltage test (75 kV)
- Partial discharge test
- Patented system
- The complete equipment is basically maintenance-free
- Safe and easy-to-handle partial discharge and high voltage test
- Depending on the total cable capacitance, it is possible to test a complete train

References / Total over 500 measurements



EGT-75 - Laboratory

- Leoni, USA
- Used as a laboratory in the production



EGT-75 - Maintenance

- Bombardier, China
- Tested 3 cars at the same time. Approximately 70m of cables.



EGT-75 - Retrofit

- Hyundai Rotem, South Korea
- Tested several trains KTX II

Services

ALPHA-ET offers a wide range of services in Traction business for train manufacturers, service providers and train operators.



Installation / Supervision

If required, we mount the cables and cable terminations on the carriages and give practical tips.



Cable length determinat.

For the first train set we do cable length determination on site on the train.

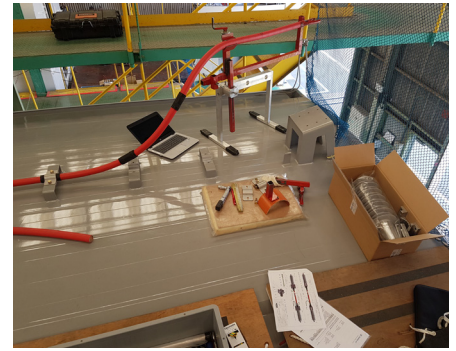

Repair / Replacement

If there is any failure on a component our specialist will repair it and/or perform replacement on site.

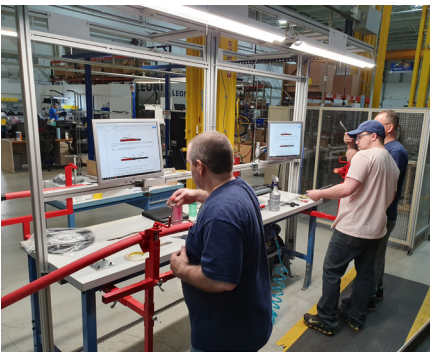

Training

We support you with instructions and trainings for your quality and maintenance teams.

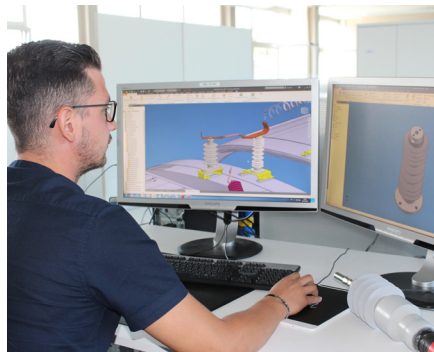

Engineering

Let us know your requirements and we will present you a solution. Our engineers devise solutions that meet customers' needs.



Retrofit

ALPHA-ET is a specialist on retrofit solutions of high voltage cables and jumpers for maintenance.

EGT-75

With the mobile partial discharge equipment EGT-75 from ALPHA-ET, our customer can test the high voltage cable solution after assembling and mounting on the train.

We offer the following services with the EGT-75:

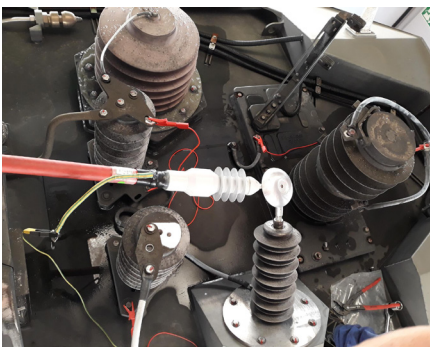

Measurement

Safe partial discharge and high voltage measurement on site on the mounted cables by our specialist.



Operator Training

Learn how to operate the EGT-75 safe and efficient. Get familiar with the test set-up and basic interpretation of measuring results.

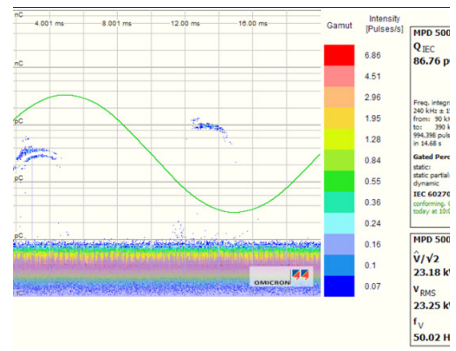

Interpretation

In case of doubts about your PD patterns, we give you support about the interpretation of the measuring results.

Services – Case study retrofit

ALPHA-ET has a wide international expertise for retrofit solutions for high voltage cables and jumpers. We offer the exchange of the complete cable or only exchange of the cable termination. The sequence of a retrofit project is presented in the following images.

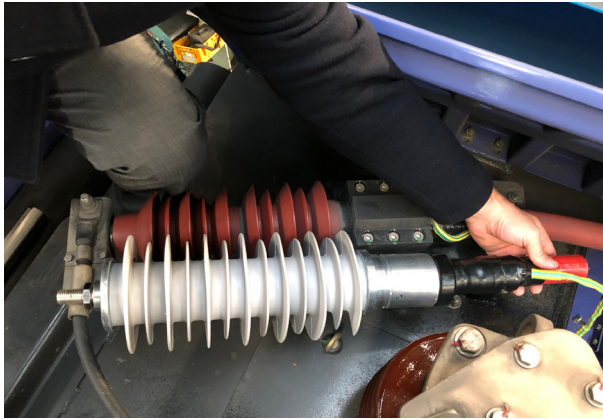

Step 1: Analysis of the installed components, on site on the train or at ALPHA. Examination of the interchangeability of components.

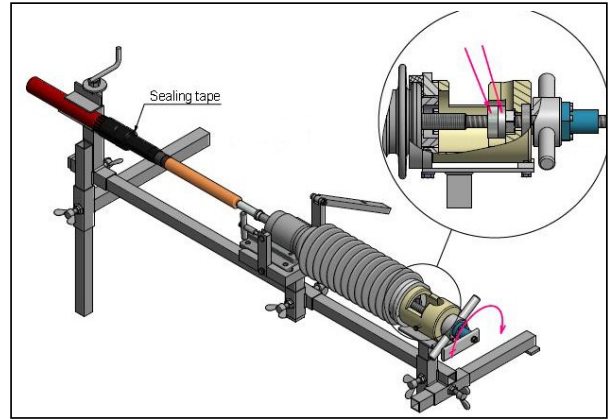

Step 2: Feasibility analysis for retrofit installation: Engineering prototype, tool development, drawings and assembly instructions.



Step 3: On-site execution: Assembly and approval of prototype. Electrical routine test of new installed components on the train. Training of local maintenance personnel. On-site execution of the complete retrofit by ALPHA-ET engineers or by trained local maintenance personnel.



Step 4: After a retrofit with exchange of termination on the train, we recommend to perform a partial discharge test of the retrofit cable with EGT-75 to guarantee the quality of the assemble process.

References Retrofits: Total over 50 projects



ETR 500, ETR 480

- Trenitalia, Vicenza, Italy
- several retrofits
- bushing and jumpers 3 and 25 kV including on site testing



ICE 3

- Deutsche Bahn, Germany
- exchange of over 400 rigid terminations on the roof including customer training and testing

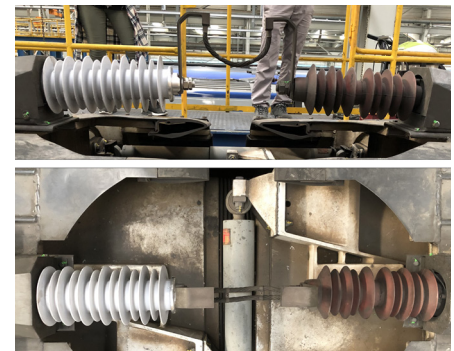

KTX II

- KORAIL, Soth Korea
- exchange of over 300 rigid terminations on the roof including customer training and testing

Special Test

As a specialist of high voltage cable solutions, ALPHA-ET offers a wide range of special tests in-house or at partner facilities. Our standard solutions are already tested accordingly.

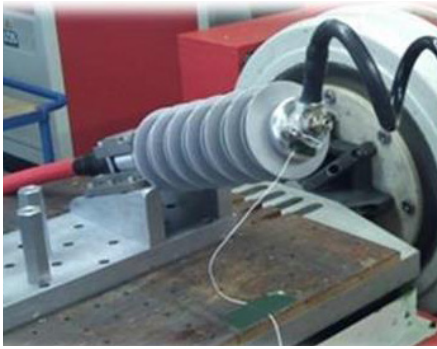

Shock and vibration

Long-term vibration according EN 60028-2-64 and EN 61373 and shock tests according EN 60068-2-27 and EN 61373.



Cold Test

Cold test according EN 60068-2-1 at -40 °C for standard solution and up to -50 °C on special demand.

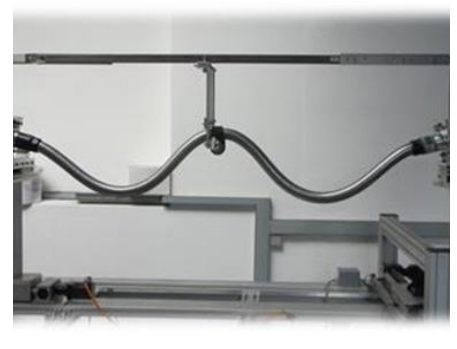

Life cycles

Life cycle test according customer requirement: Movement amplitude in x-, y-, z-axis and number of cycles.

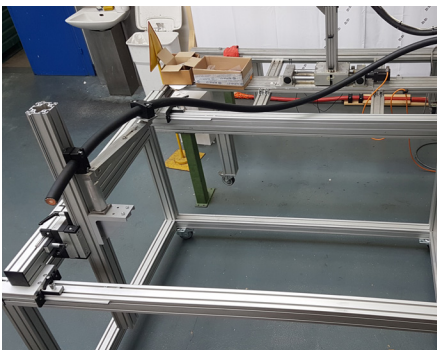

Inter car movement simulation

Movement test to check if the system can support the required displacements.



Electrical tests

Several Electrical tests as AC voltage withstand test, lightning impulse test, heating cycles test, partial discharge test, artificial rain test according IEC 61442.

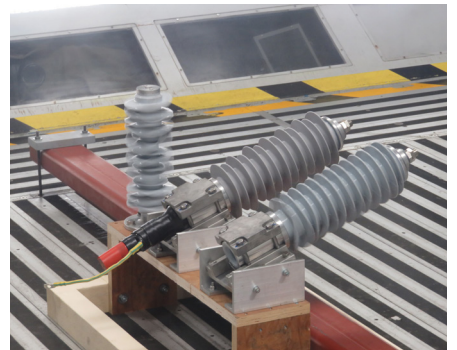

Aerodynamic simulation

Test of components and solutions in the wind tunnel to simulate wind load.

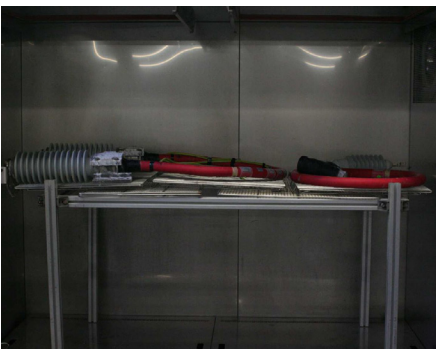

Environmental tests

Environmental testing such as dry heat test acc. EN 60068-2-2, damp heat test acc. EN 60068-2-30, salt spray test acc. EN 60068-2-11 and solar radiation test acc. EN 60068-2-5.



Fire protection

Requirement according to European standard EN 45545-2 and US standard NFPA 130.

Other tests and standards are available on request.
Our specialists will be happy to give you more details or a specific offer.

Team Traction / Contact

ALPHA Traction team is a mixture of young and experienced technicians and engineers. The team is prepared to support customers in projects, develop new products and solutions and also provide engineering and service assistance. One of the strengths of the group is a fast reaction time and also flexibility for special requirements.

We are looking forward for your contact.

Your Contact:



Rhafael Moretti
Business Unit Manager



Adi Selimovic
Project & Product Manager



Evelyn Winistörfer
Project & Product Manager



Adin Hausic
Project & Product Manager



Linus Jutzi
Product Designer



Lars Thurnherr
Service Manager

Our Traction Team



Production Team



Traction Team

DISCONNECTORS



TRACTION

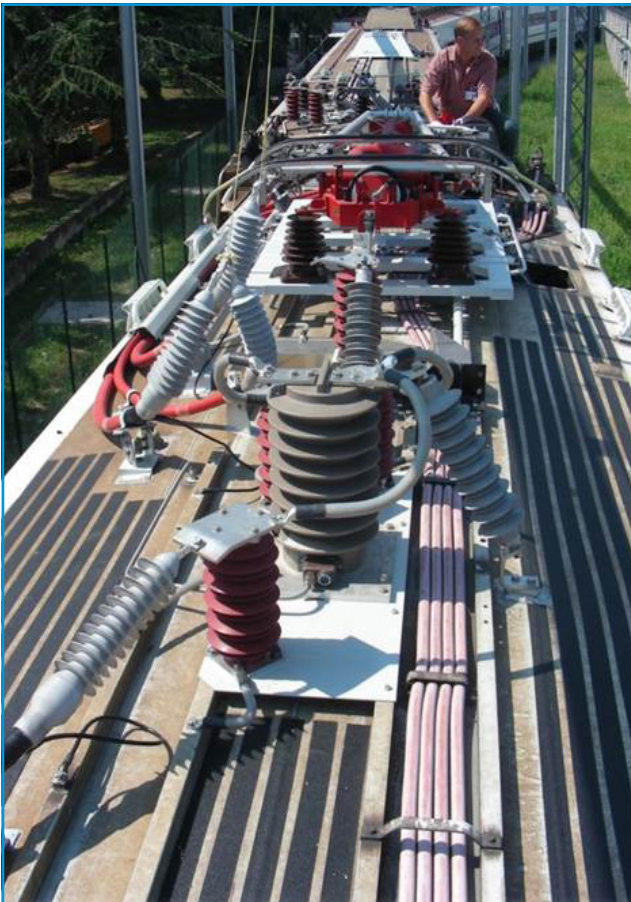

Current and voltage – our passion

ALPHA Elektrotechnik Ltd

Niklaus Wengi-Strasse 64
2540 Grenchen / Switzerland

☎ +41 32 3328700

📄 +41 32 3312679

✉ mail@alpha-et.ch

Member of PFIFFNER Group

This document has been drawn up with the utmost care. We cannot, however, guarantee that it is entirely complete, correct or up-to-date.

© Copyright ALPHA-ET
subject to change without notice V2021 07